

## APPLICATION NOTE

### Railway Train Positioning

Reporting the position of every train is an extremely important task, and leads to a number of advantages. First of all, the system prevents collisions between any two trains, in any situation. Secondly, the path of each train is determined and optimized, so that punctuality is assured. Thirdly, the train's position and speed are carefully monitored.



Tracking a train's position is possible via the placement of tags all along the railway. However, the installation and repair costs are expensive, and in some situations the train needs many types of receiver as it travels through different countries. The standard in Europe for train interlocking and signaling is the European Rail Traffic Management System (ERTMS), which relies on GNSS information.

GPS satellites offer a good solution to determine the position of a unit moving on the ground, flying in the air or sailing at sea. Nevertheless, this system shows some weaknesses, such as a lack of accuracy during cloudy weather, or a complete loss of the train's parameters while it is passing through tunnels, for example.

Whenever the positioning systems are not operational, a back-up system found in the train allows the dead-reckoning technique to be applied. It consists of estimating the position and speed of the train without any external help. Sensors such as tachometers, radars, IMUs and accelerometers are integrated in the engine. A description of each sensor is presented in the next section.

### Architecture of the System

The train positioning system calculates the acceleration, velocity and displacement of the train – absolute positioning - by exploiting the most recent information given by a tag or the GPS, and by computing the sensor data in case of dead reckoning, when GPS information is not temporally available. Sensor data increase as well accuracy and reliability of position information delivered by GPS.

An odometric system is fixed to the train. It is generally composed of the following sensors:

- Rotary encoder – installed close to a wheel to calculate the velocity and displacement
- Accelerometers – detect the acceleration due to a force applied to a structure
- Doppler radar – measures the velocity based on the reflection of microwaves

The graph shown in figure 2 explains how the accelerometer can measure a variation of position. Low-pass filters and bias correction are applied to the accelerometer's output in order to get a better estimation of velocity and displacement. The final step is to connect the displacement signal to a Kalman filter. This filter receives the data from every sensor - including GPS – and selects the most relevant one.

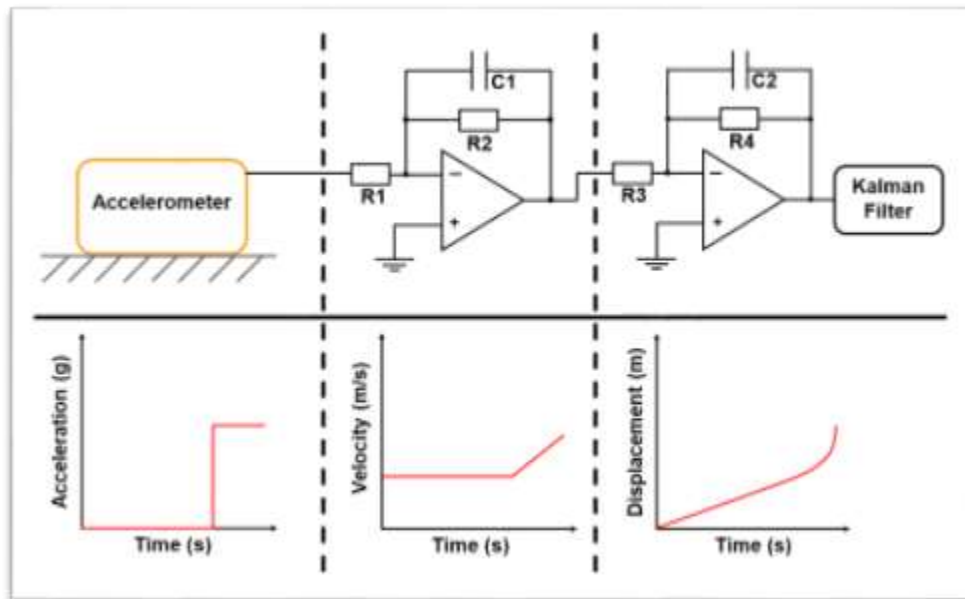

Figure 2: A simplified version of the double integrator circuit

The train needs a cluster of different sensors in order to offset their weaknesses. For example, if a wheel slips, the encoder measures a higher velocity than the accelerometer. In this case, the Kalman filter compares the value of the sensors and only considers the accelerometer's readings.

### System Requirements for Accelerometer

Train Positioning Systems accelerometer's specification for Europe and as well for China, India, Taiwan, South Korea and Saudi Arabia, has to satisfy the European Railway Traffic Management System (ERTMS) requirements for train control system. ERTMS is a major industrial project developed by eight members - Alstom Transport, Ansaldo STS, AZD Praha, Bombardier Transportation, CAF, Mermec, Siemens Mobility and Thales in close cooperation with the European Union and railway stakeholders.

Interpreting ERTMS regulations, the most important property of the sensor is its bias when no acceleration is applied to the system. The train is typically accelerated between  $\pm 0.25g$ . If not carefully monitored, bias can grow over time, and can even drown out the measurement signal. Therefore, the bias at  $0g$  needs to be small relative to the full scale.

In addition, the double integration stage generates a lot of error. The sensor needs to be extremely accurate and stable, as a small initial error leads to a massive change. As an example, figure 3 shows the variation of error in position. After each second, the error is amplified proportionally to the accelerometer's accuracy.

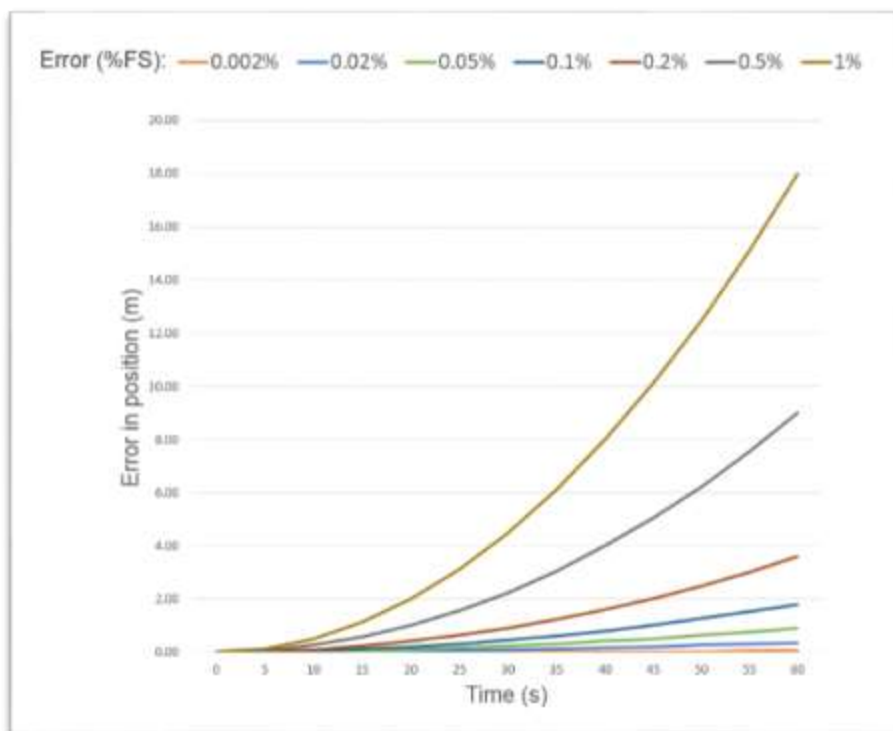

Figure 3: The variation of error after double integration over one minute

The inertial sensors are located in the locomotive: thermal variation and repetitive vibrations are thus controlled and may be neglected in this situation. A point to stress is that the accelerometer is embedded in a mobile system: it must be reliable, safe and durable. The sensor must be able to function for years, if not decades.

## MEMS is an Optimal Technology for the System

The specifications needed for this application restrict the choice of sensors available in the market. Servo-balanced accelerometers fit with the conditions of dead-reckoning in terms of precision, despite their expensive prices and large dimensions.

MEMS technology improves every year in performance and size. Nowadays, MEMS accelerometers could match the criteria imposed by ERTMS positioning requirements. The bulk micromachined accelerometers measure precisely a variation of acceleration by a change in capacitance. The angle of the cantilever between the two electrodes is directly related to the acceleration. The production is made in clean rooms using silicon wafers. The wet-etching technique allows not only efficient productivity, but also excellent MEMS quality.

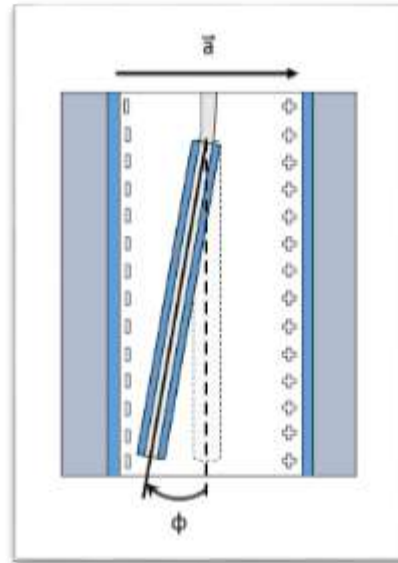

Figure 4: The principle of MEMS capacitive sensor

## MS1000 – an optimal accelerometer for Train Positioning

Safran Colibrys is a Swiss company that produces highly accurate sensors for multiple sectors, including railways. Colibrys accelerometers has been proved so far to be embedded in aeronautical applications at the safety critical level,. For railways train positioning a lower range of measurements +/- 2 g, will be required.

A new tactical grade MS1000 in 2g version will fully correspond to ERTMS railways safety and accuracy standards.

MS1002 breakthrough performances for inertial accuracies. The Initial Bias residual accuracy over a temperature range -40 to 85°C is better than 140 µg (70ppmFS, Typ) The long term bias ~~composite~~ repeatability will be better than 240 µg (120 ppmFS,typ) , thus ensuring very accurate measurements for train navigation systems. MS1002 has as well a very high resolution of 7 µg RMS (1Hz) and excellent in run bias stability of 3 µg and its LCC20 package is in hermetically sealed to guarantee measurements accuracy, reliability and durability in time.

## Glossary:

- ETMS: European rail traffic management system
- FS: Full scale
- GNSS: Global navigation satellite system
- GPS: Global positioning system
- Hz: Hertz
- IMU: Inertial measurement unit
- MEMS: Microelectromechanical system